



PRODUCT GROUPS / SHAPE
All forms, all size, all designs
everything is possible



+ Dierk Franke Akkumulatoren GmbH -



CONTENTS



Industrial Product line



Shaped Battery Production



2019 RD Roadmap for Shaped Battery



New Projects and developments





1

Industrial Product line



Capabilities

- Grepow is one of the leading manufacturers in high rate discharge cells
- All cells are produced in stacking technology; patented envelop structure is available to increase safety in case it is required.

- Stacking technology
 - High performance,
 - Low iR,
 - High safety,
 - Less heat generation

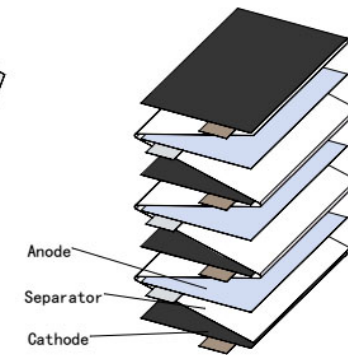
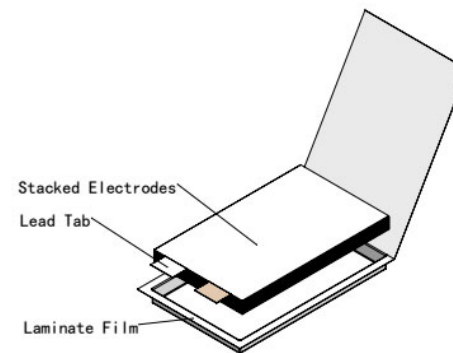



Capabilities & Limitations

- Formats: from - to
 - L: 10 mm – 260 mm
 - W: 6 mm – 160 mm
 - H: 0,4 mm – 10,5 mm
- C Rates from 1C – 45C
- NiMH: 1,2V
- LiFePO₄: 3,2V
- LiPO: 3,7 – 3,9V Systems
- Low temperature and high temperature systems available
- Capacity: depending on the size , C-rate and construction
- Energy density: depending on the size, C-rate and construction up to 270 Wh/kg
- MOQ: from 1000 pcs on depending on the type
- Production output: over 320.000 Ah per day



Product Industrial

- Wide product range (1000 standard types of cells)
- High rate discharge cells
- High selection grade on demand
- Quality control system with data storage (barcode system)
- Standard packs & packs with iBMS
- Low MOQ and tooling cost on new cell types



Li-Po cells



Product Industrial



+ Dierk Franke Akkumulatoren GmbH -

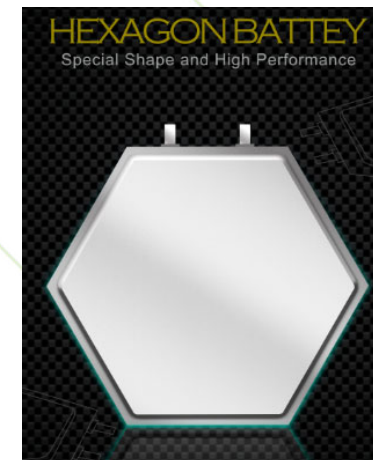
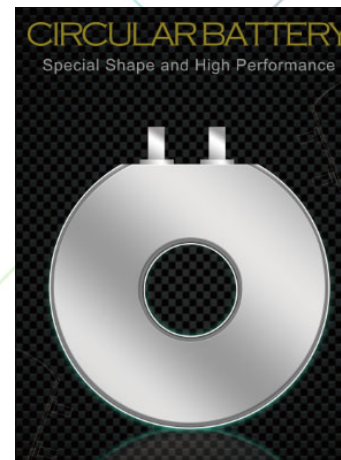
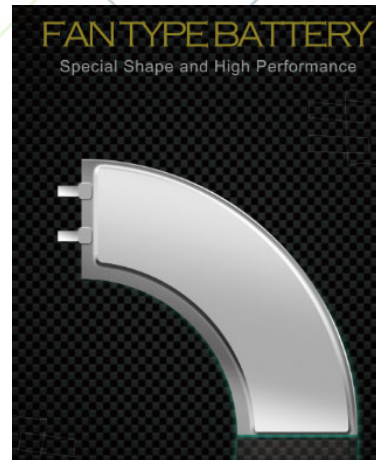
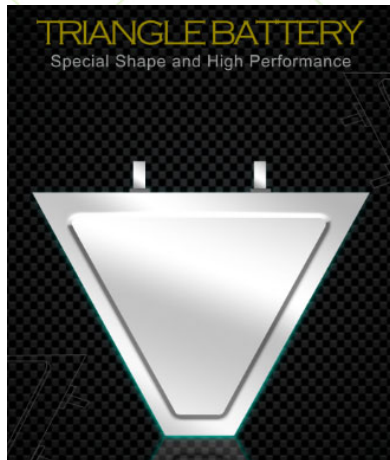
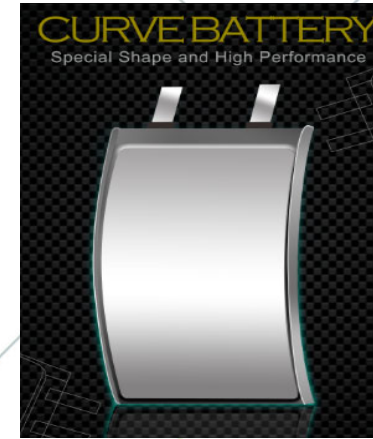
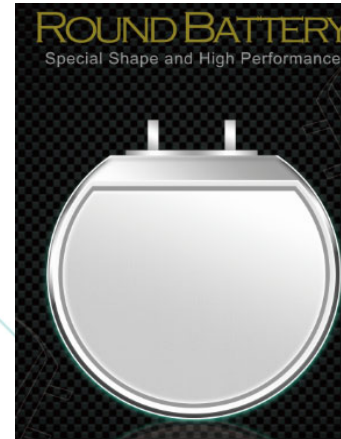
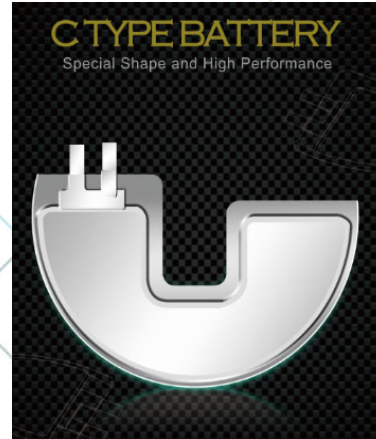
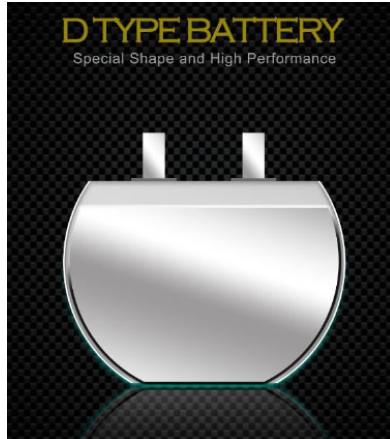

Shaped & curved Li-Po cells / customised cells





Product Industrial

- Wide range (~ 390 different types of cells)
- High production volume
- Low MOQ
- Pack assembling
- High & low temperature series
- High rate discharge cells
- Low self discharge cells



NiMH cells



Product Industrial

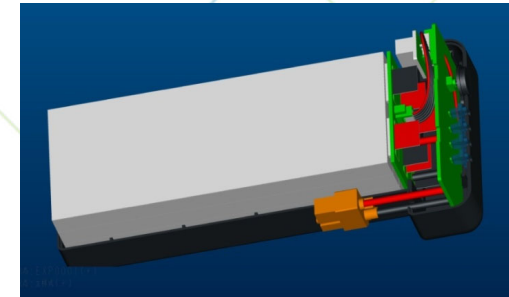
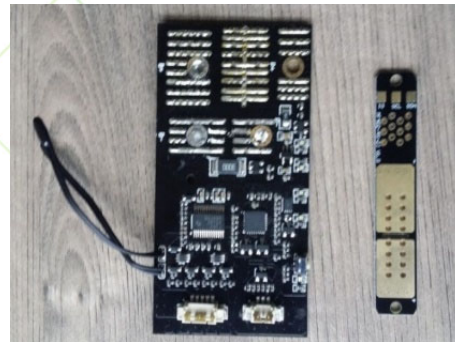
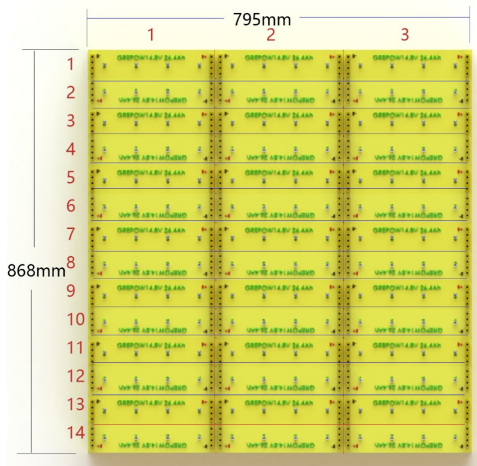
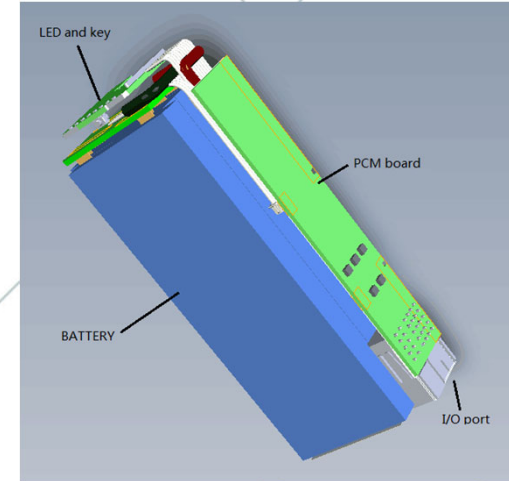
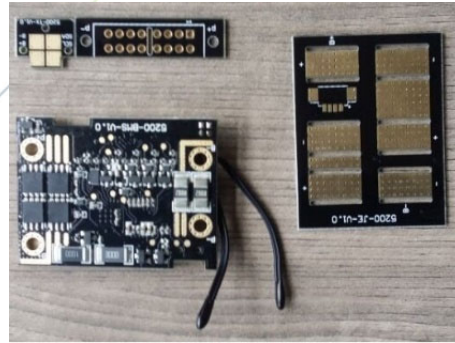
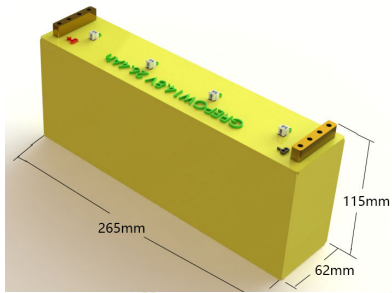

Customized Battery packs & BMS Systems



2

Shaped Battery Production

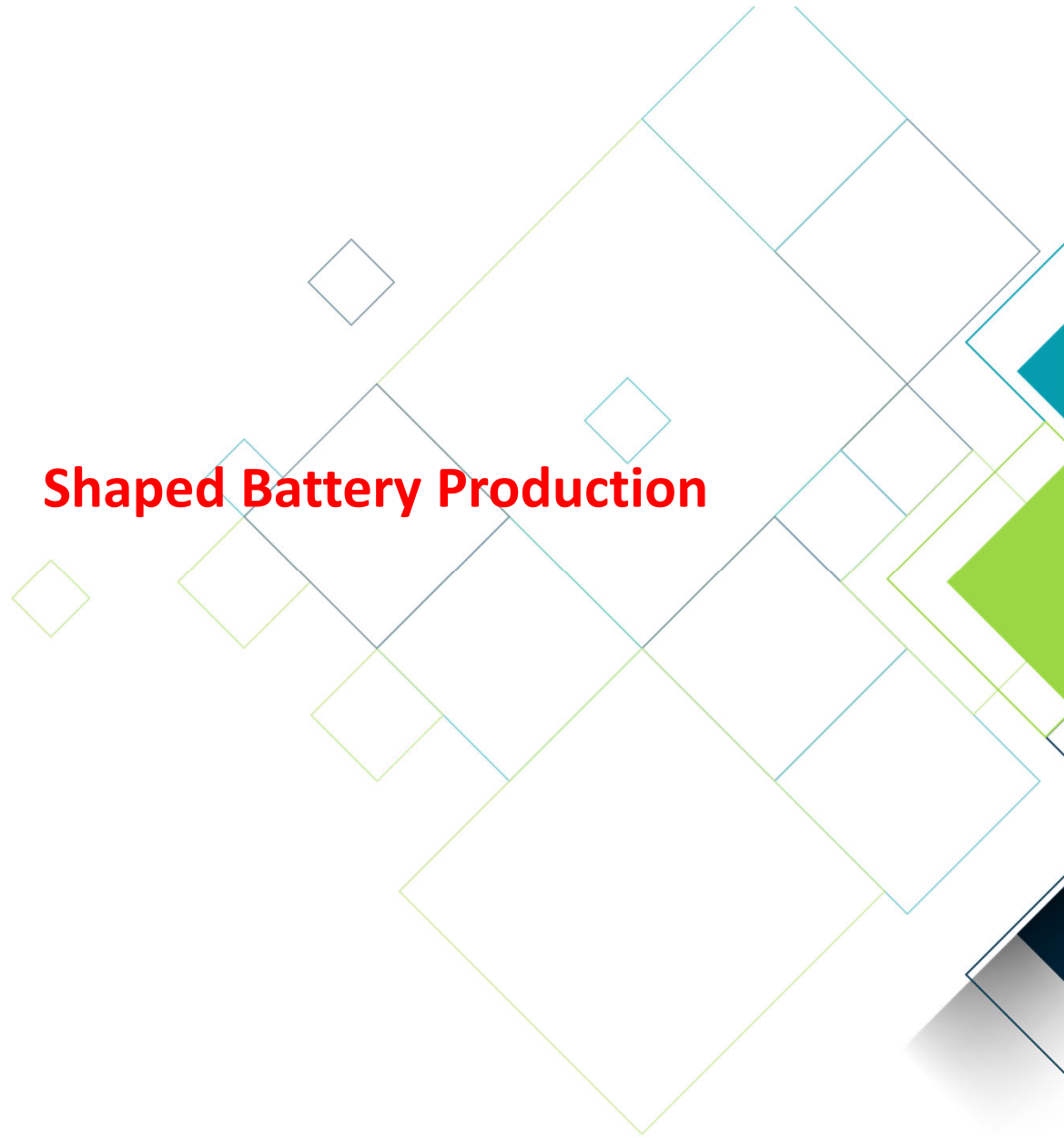



Shaped Batteries

possible forms

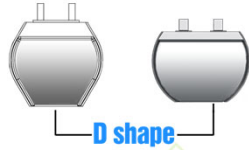
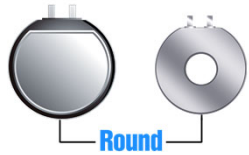

Advantages

- Increase runtime
- Minimize the size of your device
- Increase wearing comfort
- Change the form factor of the device
- Subdivide from your competitors
- Independence of product design from regular battery forms

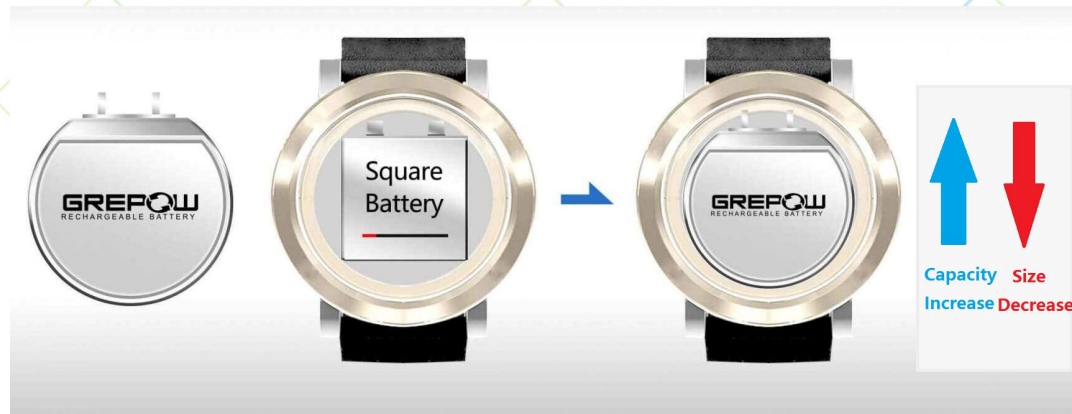



Shaped Batteries

Examples

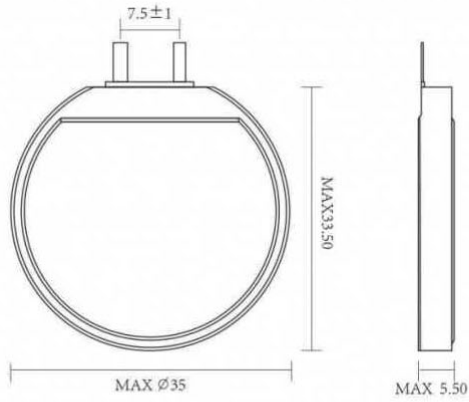

A

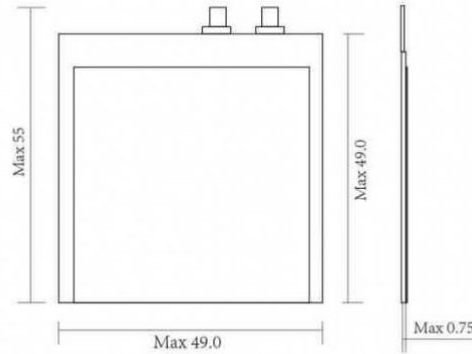

B

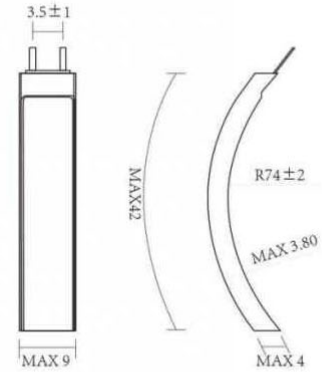

C

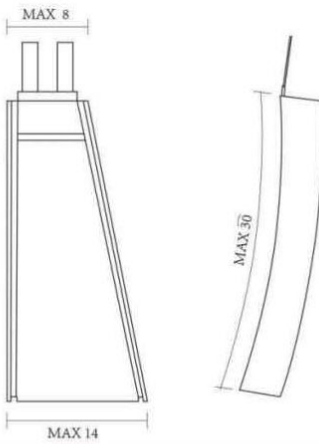

D

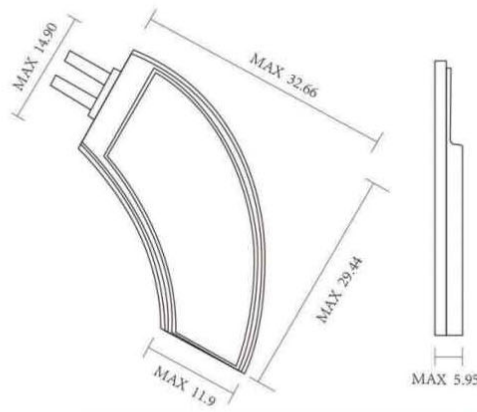

E

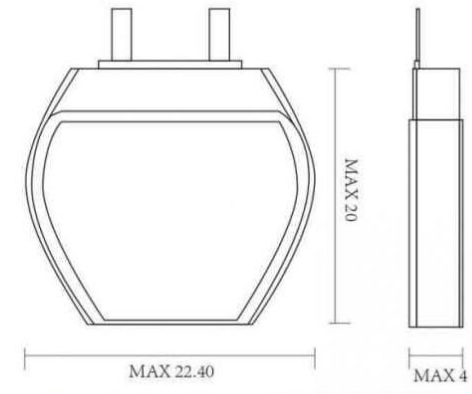

F





Shaped Batteries

Examples





Shaped Batteries

Capabilities of the shape production

Shaped Batteries

- Formed LiPO cells, on customer request (step files required)
- Evaluation and assessment free of charge
- Cells can be fitted to your application in terms of
 - Form
 - W: 6mm -> 50mm
 - L: 19mm -> 70 mm
 - H: 0,45mm -> 7,5 mm
 - Capacity will be evaluated depending on the given form, dimensions and c-Rates...
- Relatively low MOQ depending on the complexity of the form
- Tooling cost depending on form
- Production time
 - For samples 60 days
 - Mass production 90 days



Shaped Batteries

New Technologies in Production 2019

- Max voltage rise from 4.20V up to 4.40V
- Battery performance: 1C~20C
- Cycle life: 500 times or more, 0.5 °C / 80%, normal temperature cycle
 - 4.2V: Normal temperature: 500 cycle times or more, 0.5 C / 80%,
 - High Temperature: 60°C 300 cycle times
 - 4.35V: Normal temperature: 500 cycle times or more, 0.5 C / 80%,
 - High Temperature: 60°C 200 cycle times
- Super conductive additive
- New separator with ceramic/binder coating
- Super low resistance welding method (2 patents)
- Separator envelop structure to make a flexible cell (7 patents)
- Safety design pattern for high discharge rate cell(2 patents)



Advantages of Grepow Cells

Safety

- Special NMC in catode material, to increase battery safty and cycle life
- Ceramic coating seperator, to increase the safty of the cells
- Special electrolyte that could handle high temperature and to lower the risk of swelling
- Our cells have a patented electrode sheet to lower the risk of an internal short curcuit

Performance

- Excellent high current discharge capability
- Excellent high current charge rates
- Higher discharge platform or average voltage under load
- High usable energy (Wh) under load
- Lower IR by stacking technology pouch cell

Relyability

- High usable energy (Wh) under load
-> low loss of performance over the worktime
- Light weight at high energy density
- Lower temperature increase during discharge and charge
-> lower risk to get over heated
- Compact format
- Customized size, flexible cell sizes
- Good price / power value

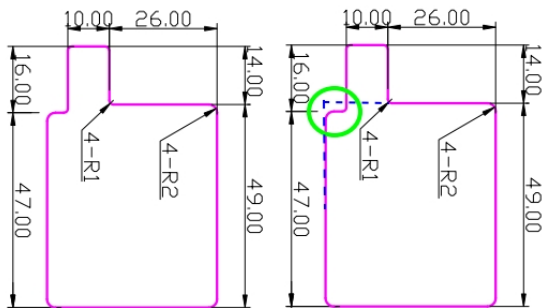



3

**2019 RD Roadmap for Shaped
Battery**

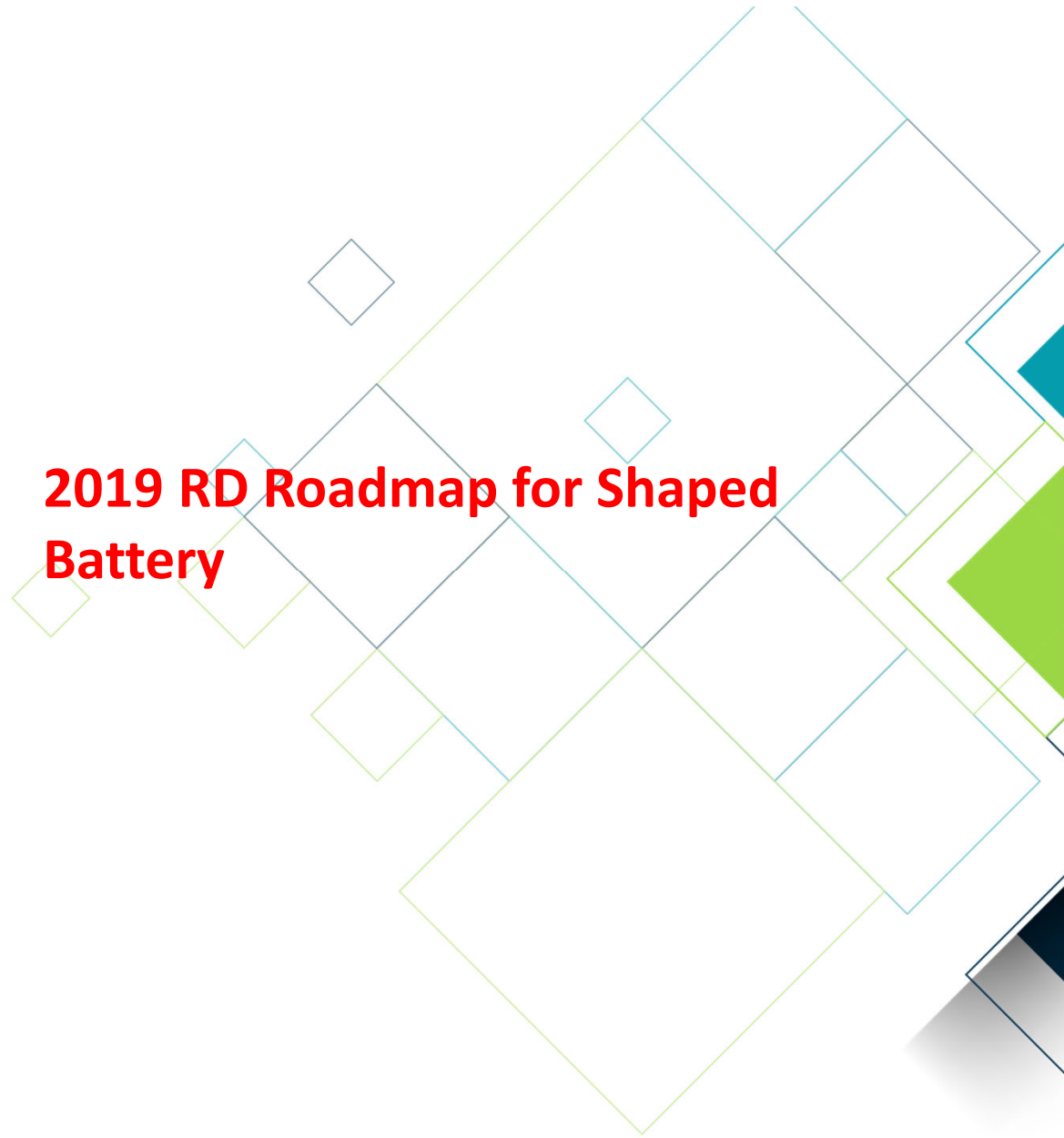



Shaped Batteries

Production Capabilities (Based on >4mm in thickness)

6 production lines (2018)

3k/line/day=18k/day (2018)

10 production lines (Now)

5k/line/day=50k/day (Now)

New types Coin Cells

A. $20\text{mm} < D < 35\text{mm}$

B. $10\text{mm} < D < 20\text{mm}$

Sample and MP in Q2,2019

Sample and MP in Q4,2019





Shaped Batteries

Performance improvements

- Increase energy density (high Voltage system / new materials).
- Increase of cycle life.
- Improve charge and discharge rates.
- High and low temperature storage.





Shaped Batteries

Developments

Volumetric Energy Density Roadmap of Shaped Cell as well as for square types (based on GRP281826-120mAh as an example)

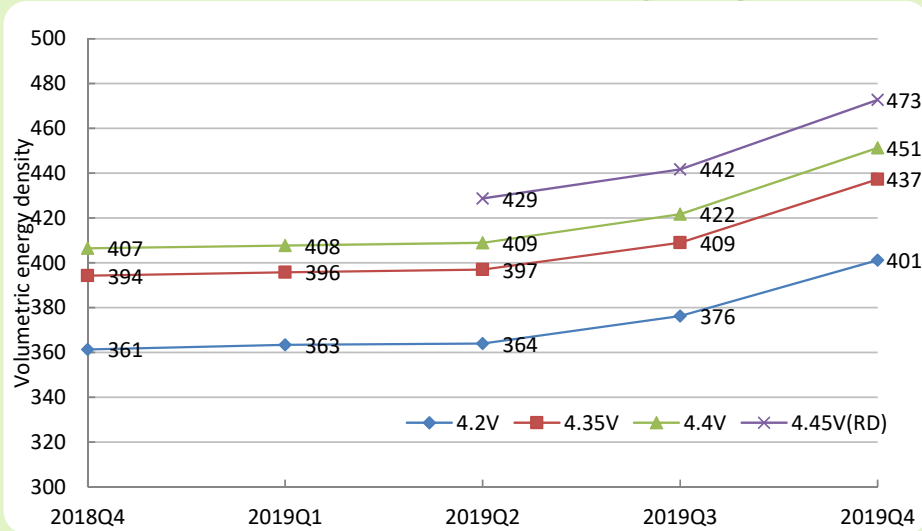

Cycle Life Roadmap for Wearable Cell at 1C charge

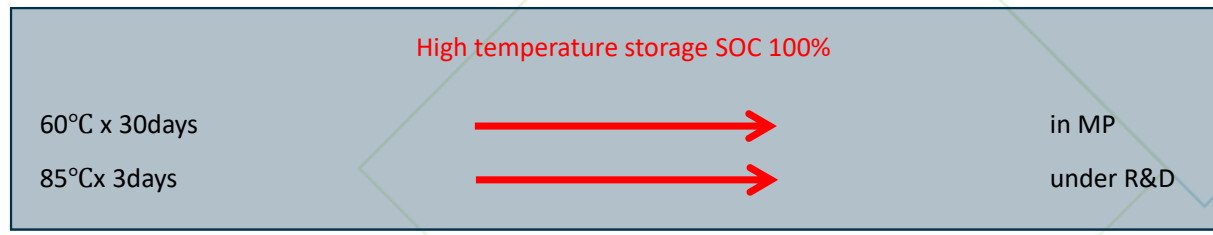
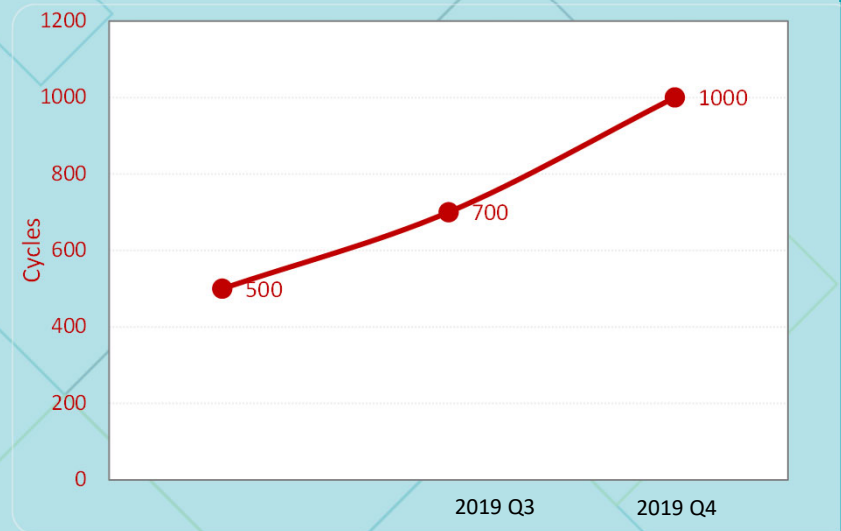



Production Roadmap

New Materials to increase energy density

- Lighter materials have been applied for UAV and other high C-rate cells; such as 6um thickness Cu foil, 12um thickness Al foil in 2018.
- New battery types with an end of charge Voltage of 4.4V will be in mass production in 2019.
- Anode material of SiO_x/C is under development to increase the energy density.
- Cathode material of 622, 811 LNCM is under testing to further increase the energy density.





4

New Projects and developments





New Projects

How can we support you better in your creation process?

- Needs
- Requirements
- Must
- Informations
- ...

If you give us an Idea about the available Room for the cell and the required performance on charging and discharging, we can provide to you the fitting solution in a very short period of time.





THANK YOU
THANK YOU
for your attention

