



LBOARD E200-S RIVA DE

Exit luminaire in compliance with EN 60598-1/2-22 and EN 1838.

One-sided exit luminaire in white for recessed ceiling mounting made of sheet steel for dynamic escape route guidance.

The pictogram of the luminaire is able to indicate two different states (evacuation and blocking).

An evacuation arrow direction (one-sided) can always be selected and must be specified separately when ordering.

The blocking symbol is an integral part of the disc and therefore cannot be deselected.



Technical specifications

Luminaire type	Luminaires for central battery systems
Illuminant	1 W LED-bar
Visibility distance	23 m
Connecting terminals	3 x 2.5 mm ² for double assignment
Connecting terminals RIVA	2 x 1.5 mm ² for double assignment
Colour	white
Material	Sheet steel
Mounting type	Recessed mounting
Dimensions (W x H x D)	DE 325 x 201 x 74 mm
Pane dimensions (W x H x D)	248 x 148 x 10 mm
Dimensions ceiling cutout (L x W)	min. 308 x 60 mm / max. 314 x 65 mm
Installation depth	97 mm
Protection class	IP40
Safety class	I
IK Safety class	IK03
Light current (mains)	130 lm
Power consumption	4.5 VA
Battery current input	11 mA
Voltage supply	230V 50/60Hz; 220V DC +25/-20%
Temperature range	-10°C to +40°C
optional	ELC MSÜ3 SET009 SET010
Multi-switch and monitoring module	

Recessed mounting

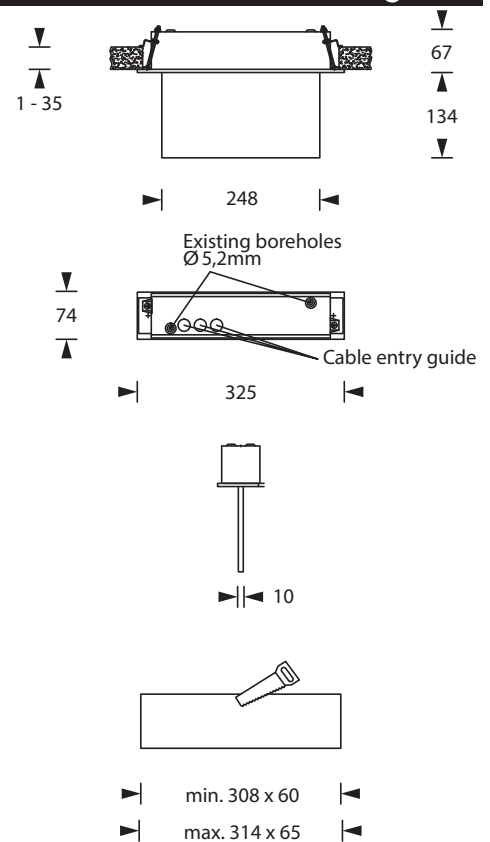

Pictograms to choose from - please specify when ordering



Accessories

- Cement assembly box
- Pictograms

Scenario 1: Fire in area A ⇒ Fire alarm system gives control signal to rescue signs 2.1 and 2.3 and blocks (red X) so that no persons run into or through the dangerous area

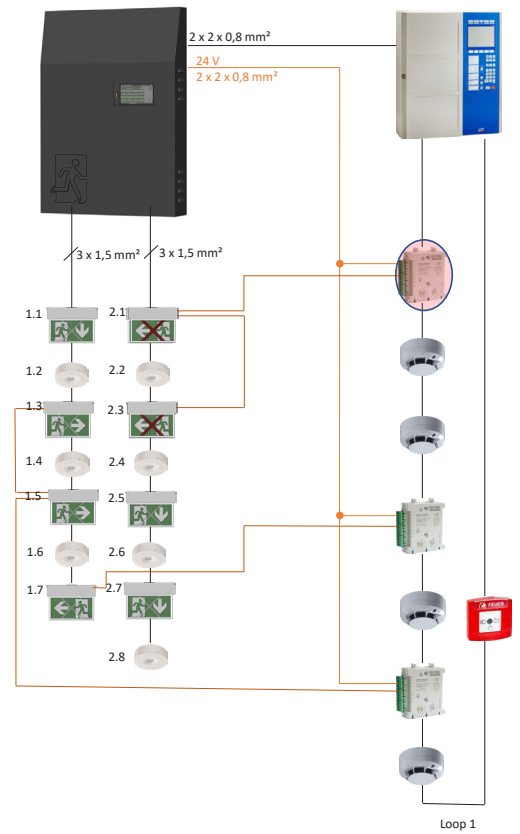
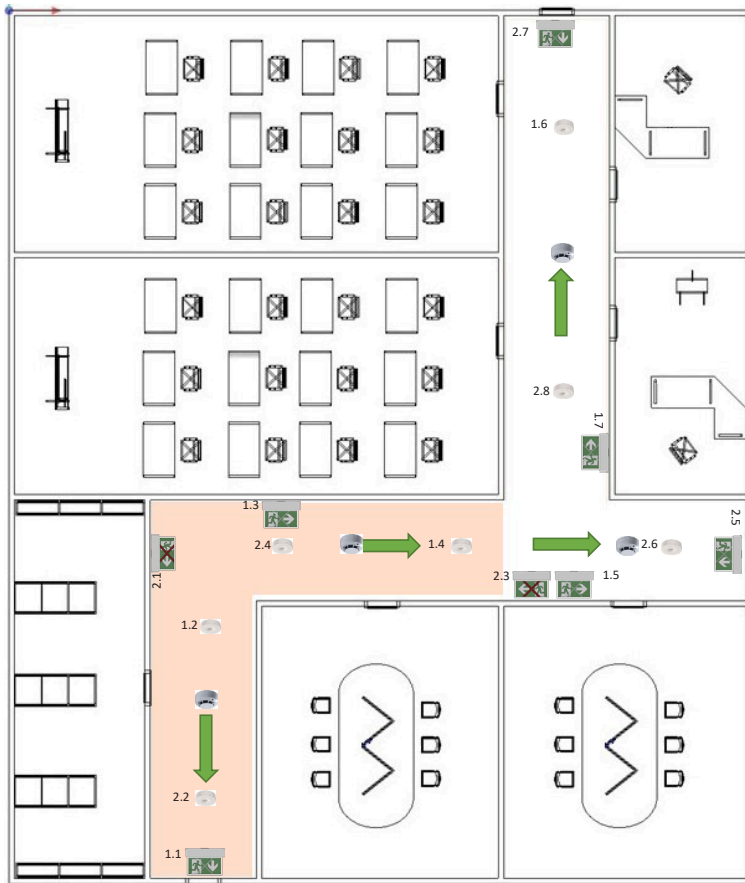

Scenario 2: Fire in area B ⇒ Fire alarm system gives control signal to rescue sign 1.7 and locks (red X) so that no persons can run into the dangerous area

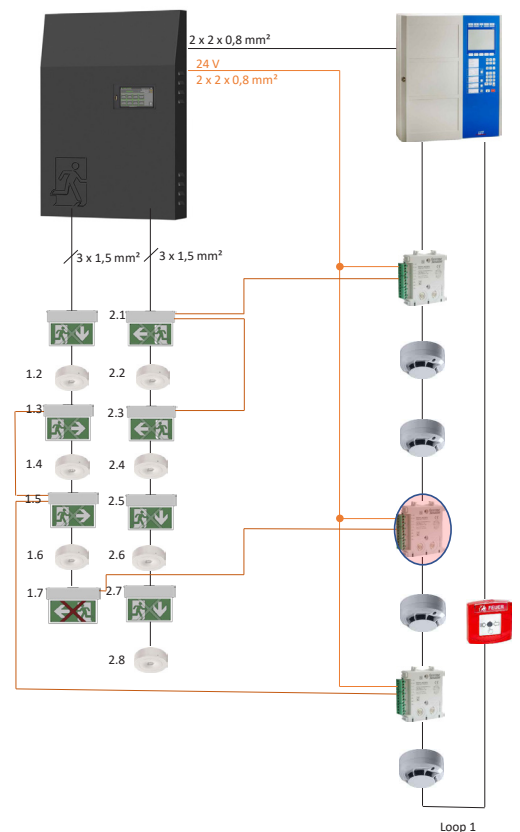
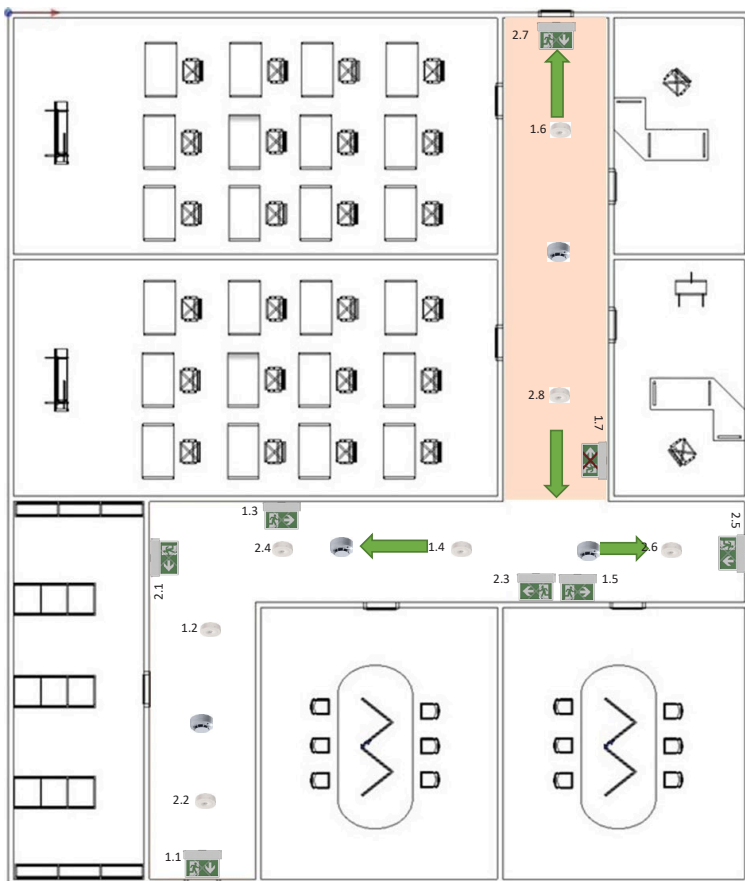

Scenario 3: Fire in area C ⇒ Fire alarm system gives control signal to escape signs 1.3 and 1.5 and blocks (red X) so that no people run into or through the dangerous area

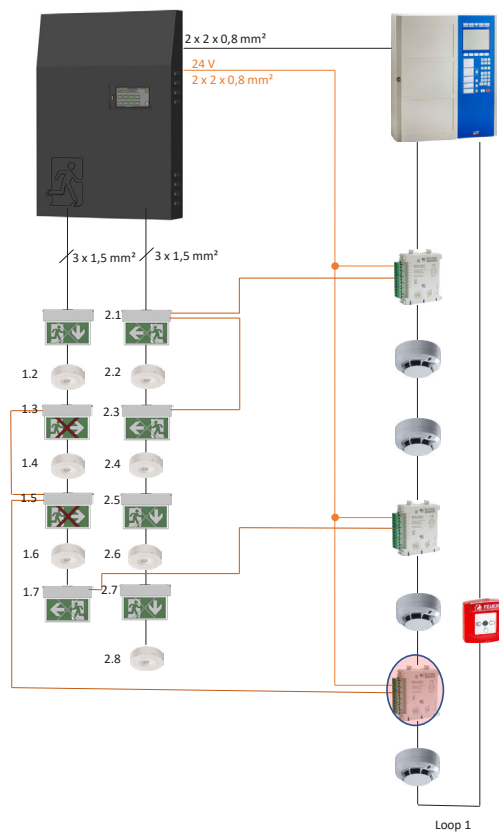
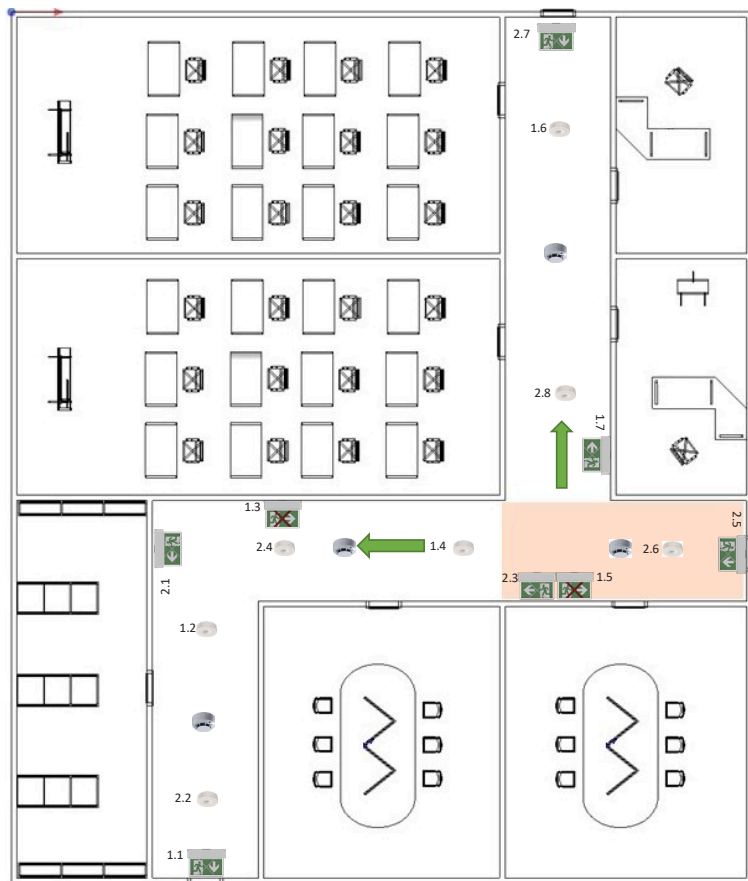

Connection diagram (example): RIVA luminaires in connection with fire alarm system and CPS/LPS

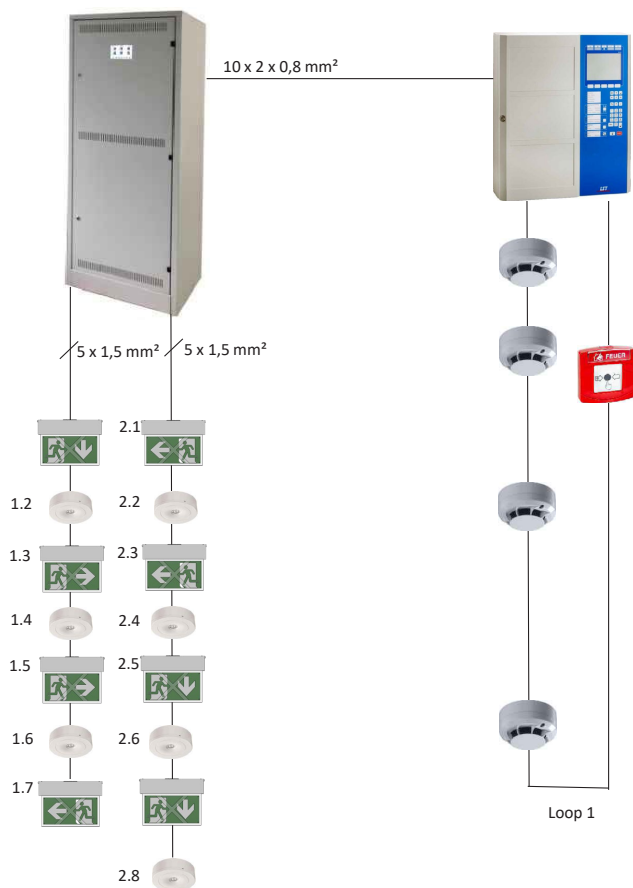

NOTE:
The exact wiring diagram must be requested from the manufacturer of the fire alarm system or CPS / LPS-System