



SBOX 300 WM

Exit luminaire in compliance with EN 60598-1/2-22 and EN 1838.

Very robust exit luminaire made of powder-coated sheet steel in white for wall mounting. The luminaire is equipped with an IP65 membrane pressure compensation valve and a 8 mm polycarbonate pane as standard.

The luminaire is equipped with a 6 Watt LED-bar and is supplied with a pictogram set - arrow left/right/down/up/blind (Visibility distance 34 m).



Technical specifications

Luminaire type	Luminaires for central battery systems	Self contained luminaires
Illuminant	6 W LED-bar	6 W LED-bar
Visibility distance	34 m	
Connecting terminals	3 x 2.5 mm ² for double assignment	
Colour	white	
Material	Sheet steel	
Mounting type	Wall mounting	
Dimensions (W x H x D)	WM 384 x 234 x 101 mm	
Protection class	IP65	
Safety class	I	
IK Safety class	IK10	
Light current (mains)	600 lm	600 lm
Luminous flux		
Emergency (DC) / mains		
Rated operating time 1h	-	30% / 100%
Rated operating time 3h	-	30% / 100%
Rated operating time 8h	-	15% / 100%
Power consumption	10.3 VA	12.5 VA
Battery current input	27 mA	-
Battery duration	-	1h / 3h / 8h
Battery operation		
Voltage supply	230V 50/60Hz; 220V DC +25/-20%	230V 50/60Hz
NiMH-battery		
Rated operating time 1h	-	4,8V 2,0Ah
Rated operating time 3h	-	4,8V 2,0Ah
Rated operating time 8h	-	4,8V 2,0Ah
Temperature range	-10°C to +40°C	-
Non-maintained mode	-	0°C to +35°C
Maintained mode	-	-5°C to +30°C
optional		
Multi-switch and monitoring module	DALI ELC MSÜ3 SET009 SET010	-
Self monitoring	-	SELF CHECK
Central monitoring	-	SAFELOG Line
Wireless monitoring	-	SAFELOG Wireless

Wall mounting

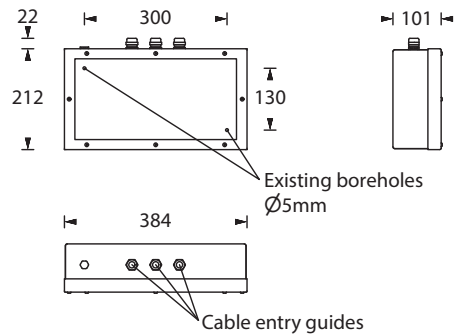

Pictogram-set - included in the delivery

