



L-STAR AW-F

Safety luminaire according to EN 60598-1/2-22 and EN 1838.

Narrow, visually appealing housing, consisting of a polycarbonate mounting plate and a sheet steel housing, powder-coated in white. Version for wall mounting with cast acrylic optics for area illumination due to circular light control characteristics.

The luminaire is equipped with a 3 Watt power LED.

Technical specifications

Luminaire type	Luminaires for central battery systems	Self contained luminaires
Illuminant	3 W LED	3 W LED
Connecting terminals	3 x 2.5 mm ² for double assignment	
Colour	white	
Material	Sheet steel/Polycarbonate	
Mounting type	Wall mounting	
Dimensions (W x H x D)	WM 64 x 284 x 67 mm	
Protection class	IP40	
Safety class	I	
IK Safety class	IK03	
Light current (mains)	280 lm	120 lm
Light current (emergency)		
Rated operating time 1h	-	280 lm
Rated operating time 3h	-	280 lm
Rated operating time 8h	-	120 lm
Luminous flux		
Emergency (DC) / mains		
Rated operating time 1h	-	100% / 45%
Rated operating time 3h	-	100% / 45%
Rated operating time 8h	-	45% / 45%
Power consumption	6 VA	5 VA
Battery current input	15 mA	-
Battery duration		
Battery operation	-	1h / 3h / 8h
Voltage supply	230V 50/60Hz; 220V DC +25/-20%	230V 50/60Hz
NiMH-battery		
Rated operating time 1h	-	4,8V 2,0Ah
Rated operating time 3h	-	4,8V 2,0Ah
Rated operating time 8h	-	4,8V 2,0Ah
Temperature range	-10°C to +40°C	-
Non-maintained mode	-	0°C to +35°C
Maintained mode	-	-5°C to +30°C
optional		
Multi-switch and monitoring module	DALI ELC MSÜ3 SET009 SET010	-
Self monitoring	-	SELF CHECK
Central monitoring	-	SAFELOG Line
Wireless monitoring	-	SAFELOG Wireless



Wall mounting

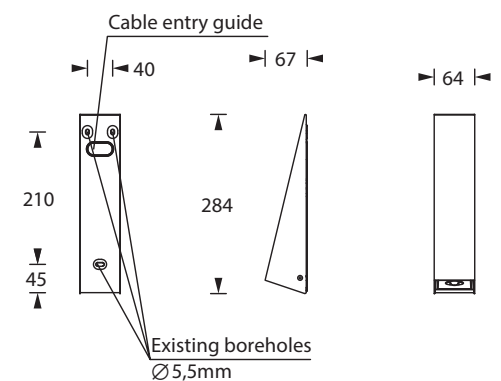

Lighting data and tables of luminaire distances (E = 1,25 lx)

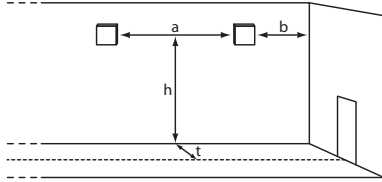

Wall mounting

Luminaires for central battery systems wide area optics

Distance table for plane emergency routes / distance data in meters

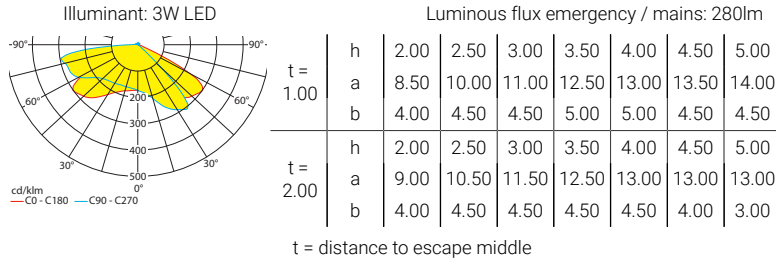

Self contained luminaires wide area optics

Distance table for plane emergency routes / distance data in meters

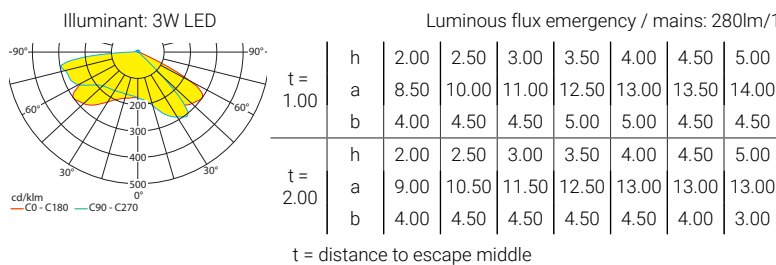

Self contained luminaires wide area optics

Distance table for plane emergency routes / distance data in meters

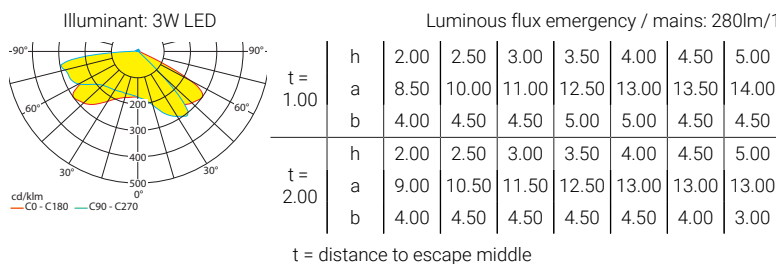

Self contained luminaires wide area optics

Distance table for plane emergency routes / distance data in meters

