

Colour



Recessed frame - set

Wall and ceiling installation frame for SMARTLUX 200 WM/BEL and SMARTLUX 300 WM/BEL series made of white polycarbonate.

The wall and ceiling installation set contains:

- Installation frame
- 2x brackets to mount the luminaire into a wall or ceiling

For concrete construction you can use the universal installation housing from the company Kaiser (Kaiser item no.: 1297-34) for wall mounting, which you have to order separate at your preferred wholesales.



Luminaires are not included in the scope of delivery

Technical specifications and order information

Colour	white
Material	Polycarbonate
Dimensions (W x H x D)	Installation frame 331 x 192 x 9 mm mounted luminaire 331 x 192 x 72 mm
Dimensions ceiling cutout (L x W)	min. 306 x 158 mm / max. 314 x 165 mm

Recessed frame SMARTLUX 300 for central battery luminaire

Order number 551232

Note

Suitable for following luminaires:

SMARTLUX 300 BEL WM/DM	SMARTLUX 300 BEL-T DM
SMARTLUX 300 BEL-R DM	SMARTLUX 300 WM

Recessed frame SMARTLUX 300 WM/BEL for self contained luminaire SC, SL, SWX

Order number 551233

Note

In terms of self-contained luminaires with manual test button, a cable connection has to be switched which leads to a disabled manual test button. For a functional test you have to disconnect the power circuit. Please see also the mounting instruction.

Suitable for following luminaires:

SMARTLUX 300 BEL WM/DM	SMARTLUX 300 BEL-T DM
SMARTLUX 300 BEL-R DM	SMARTLUX 300 WM

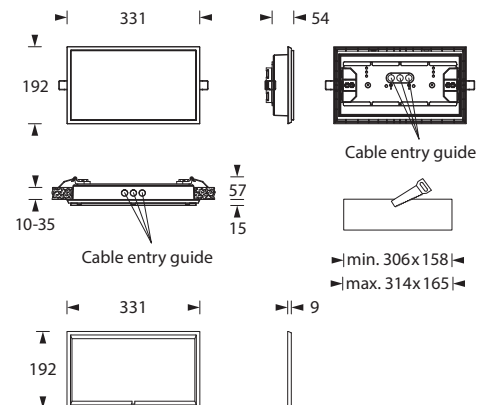

Colour	white
Material	Polycarbonate
Dimensions (W x H x D)	Installation frame 261 x 157 x 9 mm mounted luminaire 261 x 157 x 72 mm
Dimensions ceiling cutout (L x W)	min. 233 x 121 mm / max. 238 x 128 mm

Recessed frame 200 WM/BEL for central battery luminaire

Order number 551254

Note

Suitable for following luminaires:

SMARTLUX 200 BEL WM/DM SMARTLUX 200 BEL-R DM SMARTLUX 200 WM

Recessed frame SMARTLUX 200 WM/BEL for self contained luminaire SC, SL, SWX

Order number 551255

Note

In terms of self-contained luminaires with manual test button, a cable connection has to be switched which leads to a disabled manual test button. For a functional test you have to disconnect the power circuit. Please see also the mounting instruction.

Suitable for following luminaires:

SMARTLUX 200 BEL WM/DM SMARTLUX 200 BEL-R DM SMARTLUX 200 WM

