



# PROTECT BEL WM/DM

## Safety luminaire in compliance with EN 60598-1/2-22 and EN 1838.

Safety luminaire with protection class IP65 made of polycarbonate with clear light cover for surface illumination.

For unprotected outdoor installation we offer an accessory set with pressure compensation valve. In the versions with battery heating and external supply, the pressure equalization valve is always integrated in the luminaire.

The luminaire is optionally available as a set with supply unit for indoor installation and luminaire unit for outdoor installation.

Alternatively, the luminaire is available with heating container incl. battery 4.8V 4.2Ah for LED 3W and 6W (3h) / 1.5W and 6W (8h) to extend the temperature range to -20°C. Optionally, the luminaire can be supplied as a central battery variant for a temperature range down to -35°C (unmonitored).



## Technical specifications

Luminaire type	Luminaires for central battery systems				Self contained luminaires		
	1.5 W LED-bar	3 W LED-bar	6 W LED-bar	10 W LED-bar	1.5 W LED-bar	3 W LED-bar	6 W LED-bar
Connecting terminals	2 x 2.5 mm <sup>2</sup> for double assignment						
Colour	white						
Material	Polycarbonate (light cover clear)						
Mounting type	Wall-/ceiling mounting						
Additional mounting types*	Ceiling mounting (wire suspension), Pendulum mounting						
Dimensions (W x H x D)	WM/DM 370 x 140 x 94 mm						
Protection class	IP65						
Safety class	II						
IK Safety class	IK08						
Light current (mains)	190 lm	350 lm	600 lm	1050 lm	190 lm	350 lm	580 lm
Light current (emergency)							
Rated operating time 1h	-	-	-	-	190 lm	350 lm	580 lm
Rated operating time 3h	-	-	-	-	190 lm	350 lm	580 lm
Rated operating time 8h	-	-	-	-	190 lm	-	320 lm
Luminous flux							
Emergency (DC) / mains							
Rated operating time 1h	-	-	-	-	100% / 100%	100% / 100%	100% / 100%
Rated operating time 3h	-	-	-	-	100% / 100%	100% / 100%	100% / 100%
Rated operating time 8h	-	-	-	-	100% / 100%	-	55% / 100%
Power consumption	5 VA	6 VA	10.3 VA	15 VA	5 VA	6 VA	11.5 VA
Battery current input	12 mA	19 mA	27 mA	41 mA	-		
Battery duration							
Battery operation	-				1h / 3h / 8h		
Voltage supply	230V 50/60Hz; 220V DC +25/-20%				230V 50/60Hz		
NiMH-battery							
Rated operating time 1h	-	-	-	-	4,8V 2,0Ah	4,8V 2,0Ah	4,8V 2,0Ah
Rated operating time 3h	-	-	-	-	4,8V 2,0Ah	4,8V 4,2Ah + AkH	4,8V 4,2Ah + AkH
Rated operating time 8h	-	-	-	-	4,8V 4,2Ah 4,8V 4,2Ah + AkH	-	4,8V 4,2Ah 4,8V 4,2Ah + AkH
Temperature range	-10°C to +40°C						
Non-maintained mode	-				0°C to +35°C		
Maintained mode	-				-5°C to +30°C		
optional							
Multi-switch and monitoring module	DALI ELC MSÜ3 SET009 SET010				-		
Self monitoring	-				SELF CHECK		
Central monitoring	-				SAFELOG Line		
Wireless monitoring	-				SAFELOG Wireless		

\* Optional accessory required

## Accessories

Universal cover plate
Pressure compensation valve
Pole and wall bracket
Double pendulum set with long canopy
Central pendulum sets with long canopy
Central pendulum - Plastic
Wire sets with long canopy
Cable assembly set
Set for parallel wall mounting

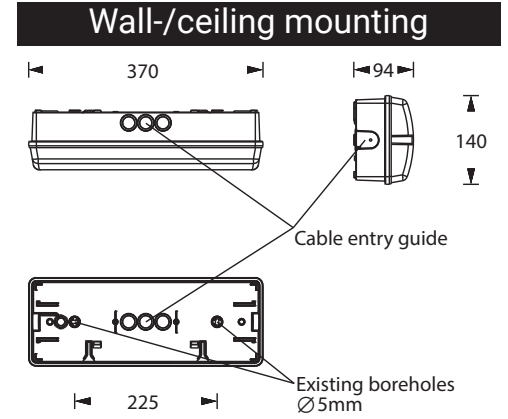

## Lighting data and tables of luminaire distances (E = 1,25 lx)

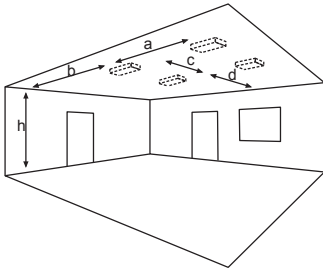

Ceiling mounting

### Luminaires for central battery systems Wide area illumination

Distance table for plane emergency routes / distance data in meters

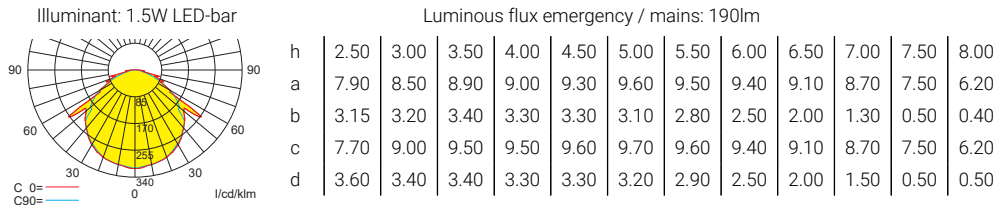

### Luminaires for central battery systems Wide area illumination

Distance table for plane emergency routes / distance data in meters

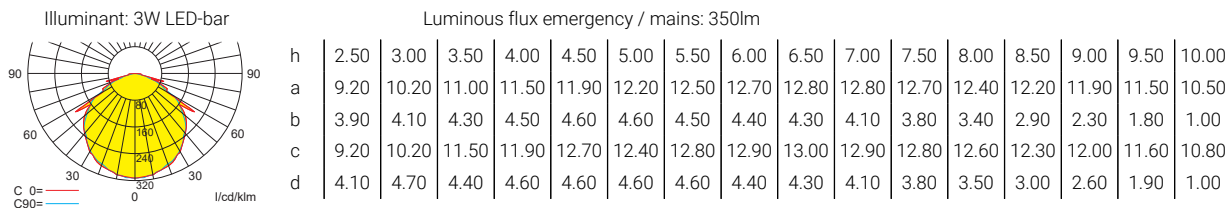

### Luminaires for central battery systems Wide area illumination

Distance table for plane emergency routes / distance data in meters

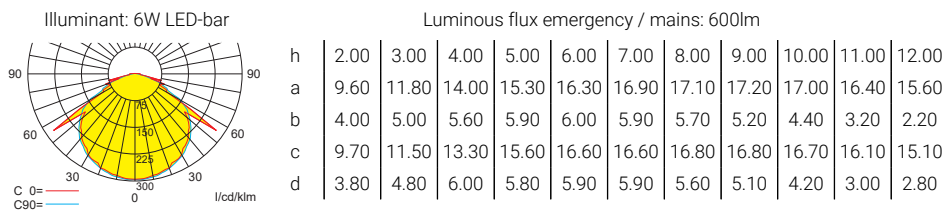

## Luminaires for central battery systems **Wide area illumination**

Distance table for plane emergency routes / distance data in meters

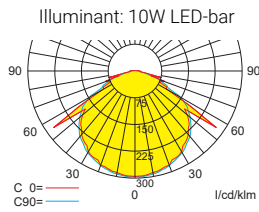

Luminous flux emergency / mains: 1050lm

h	2.00	3.00	4.00	5.00	6.00	7.00	8.00	9.00	10.00	11.00	12.00	13.00	14.00	15.00
a	10.10	13.60	15.30	17.60	19.20	20.40	21.10	21.70	21.90	22.10	21.90	21.70	21.00	20.30
b	4.30	5.50	6.60	7.20	7.50	7.70	7.80	7.70	7.40	7.00	6.30	5.50	4.20	2.00
c	10.40	12.80	15.10	16.80	19.10	20.80	21.80	21.20	21.50	21.70	21.40	21.30	20.70	19.80
d	4.00	5.30	6.50	7.60	7.30	7.60	7.60	7.50	7.30	6.80	6.30	5.20	4.00	1.70

## Self contained luminaires **Wide area illumination**

Distance table for plane emergency routes / distance data in meters

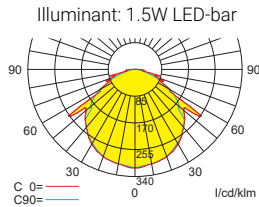

Luminous flux emergency / mains: 190lm/190lm – **Rated operating time: 1h**

h	2.50	3.00	3.50	4.00	4.50	5.00	5.50	6.00	6.50	7.00	7.50	8.00
a	7.90	8.50	8.90	9.00	9.30	9.60	9.50	9.40	9.10	8.70	7.50	6.20
b	3.15	3.20	3.40	3.30	3.30	3.10	2.80	2.50	2.00	1.30	0.50	0.40
c	7.70	9.00	9.50	9.50	9.60	9.70	9.60	9.40	9.10	8.70	7.50	6.20
d	3.60	3.40	3.40	3.30	3.30	3.20	2.90	2.50	2.00	1.50	0.50	0.50

## Self contained luminaires **Wide area illumination**

Distance table for plane emergency routes / distance data in meters

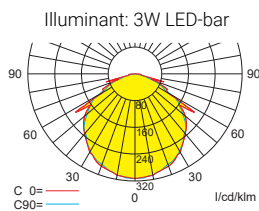

Luminous flux emergency / mains: 350lm/350lm – **Rated operating time: 1h**

h	2.50	3.00	3.50	4.00	4.50	5.00	5.50	6.00	6.50	7.00	7.50	8.00	8.50	9.00	9.50	10.00
a	9.20	10.20	11.00	11.50	11.90	12.20	12.50	12.70	12.80	12.80	12.70	12.40	12.20	11.90	11.50	10.50
b	3.90	4.10	4.30	4.50	4.60	4.60	4.50	4.40	4.30	4.10	3.80	3.40	2.90	2.30	1.80	1.00
c	9.20	10.20	11.50	11.90	12.70	12.40	12.80	12.90	13.00	12.90	12.80	12.60	12.30	12.00	11.60	10.80
d	4.10	4.70	4.40	4.60	4.60	4.60	4.60	4.40	4.30	4.10	3.80	3.50	3.00	2.60	1.90	1.00

## Self contained luminaires **Wide area illumination**

Distance table for plane emergency routes / distance data in meters

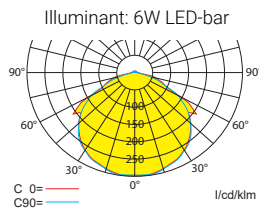

Luminous flux emergency / mains: 580lm/580lm – **Rated operating time: 1h**

h	2.00	3.00	4.00	5.00	6.00	7.00	8.00	9.00	10.00	11.00
a	9.90	12.20	14.10	15.20	16.10	16.70	17.00	17.00	16.90	16.40
b	4.20	5.10	5.60	5.90	6.00	6.00	5.70	5.20	4.40	3.10
c	10.10	12.10	14.40	16.10	16.80	16.70	17.00	17.00	16.70	16.20
d	4.10	5.30	6.00	5.90	6.00	5.90	5.70	5.10	4.30	3.00

## Self contained luminaires **Wide area illumination**

Distance table for plane emergency routes / distance data in meters

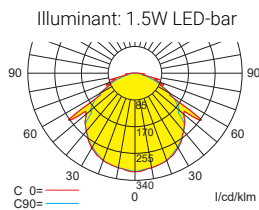

Luminous flux emergency / mains: 190lm/190lm – **Rated operating time: 3h**

h	2.50	3.00	3.50	4.00	4.50	5.00	5.50	6.00	6.50	7.00	7.50	8.00
a	7.90	8.50	8.90	9.00	9.30	9.60	9.50	9.40	9.10	8.70	7.50	6.20
b	3.15	3.20	3.40	3.30	3.30	3.10	2.80	2.50	2.00	1.30	0.50	0.40
c	7.70	9.00	9.50	9.50	9.60	9.70	9.60	9.40	9.10	8.70	7.50	6.20
d	3.60	3.40	3.40	3.30	3.30	3.20	2.90	2.50	2.00	1.50	0.50	0.50

## Self contained luminaires **Wide area illumination**

Distance table for plane emergency routes / distance data in meters

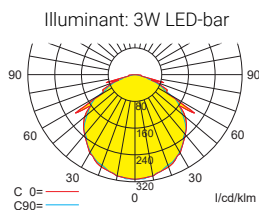

Luminous flux emergency / mains: 350lm/350lm – **Rated operating time: 3h**

h	2.50	3.00	3.50	4.00	4.50	5.00	5.50	6.00	6.50	7.00	7.50	8.00	8.50	9.00	9.50	10.00
a	9.20	10.20	11.00	11.50	11.90	12.20	12.50	12.70	12.80	12.80	12.70	12.40	12.20	11.90	11.50	10.50
b	3.90	4.10	4.30	4.50	4.60	4.60	4.50	4.40	4.30	4.10	3.80	3.40	2.90	2.30	1.80	1.00
c	9.20	10.20	11.50	11.90	12.70	12.40	12.80	12.90	13.00	12.90	12.80	12.60	12.30	12.00	11.60	10.80
d	4.10	4.70	4.40	4.60	4.60	4.60	4.60	4.40	4.30	4.10	3.80	3.50	3.00	2.60	1.90	1.00

**Self contained luminaires Wide area illumination**

**Distance table for plane emergency routes / distance data in meters**

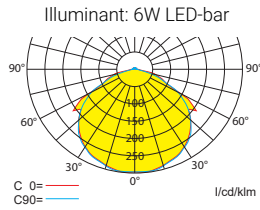

Luminous flux emergency / mains: 580lm/580lm – **Rated operating time: 3h**

h	2.00	3.00	4.00	5.00	6.00	7.00	8.00	9.00	10.00	11.00
a	9.90	12.20	14.10	15.20	16.10	16.70	17.00	17.00	16.90	16.40
b	4.20	5.10	5.60	5.90	6.00	6.00	5.70	5.20	4.40	3.10
c	10.10	12.10	14.40	16.10	16.80	16.70	17.00	17.00	16.70	16.20
d	4.10	5.30	6.00	5.90	6.00	5.90	5.70	5.10	4.30	3.00

**Self contained luminaires Wide area illumination**

**Distance table for plane emergency routes / distance data in meters**

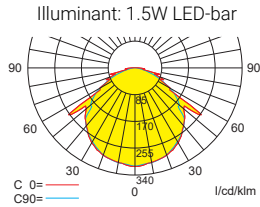

Luminous flux emergency / mains: 190lm/190lm – **Rated operating time: 8h**

h	2.50	3.00	3.50	4.00	4.50	5.00	5.50	6.00	6.50	7.00	7.50	8.00
a	7.90	8.50	8.90	9.00	9.30	9.60	9.50	9.40	9.10	8.70	7.50	6.20
b	3.15	3.20	3.40	3.30	3.30	3.10	2.80	2.50	2.00	1.30	0.50	0.40
c	7.70	9.00	9.50	9.50	9.60	9.70	9.60	9.40	9.10	8.70	7.50	6.20
d	3.60	3.40	3.40	3.30	3.30	3.20	2.90	2.50	2.00	1.50	0.50	0.50

**Self contained luminaires Wide area illumination**

**Distance table for plane emergency routes / distance data in meters**

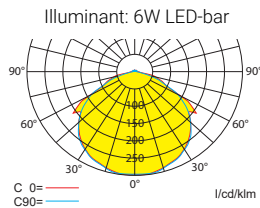

Luminous flux emergency / mains: 320lm/580lm – **Rated operating time: 8h**

h	2.00	3.00	4.00	5.00	6.00	7.00	8.00
a	8.50	10.50	11.60	12.30	12.60	12.60	12.30
b	3.60	4.20	4.40	4.50	4.20	3.60	2.50
c	8.50	10.80	12.30	12.30	12.60	12.60	12.10
d	3.70	4.40	4.40	4.40	4.20	3.60	2.50